

PMA stainless steel version

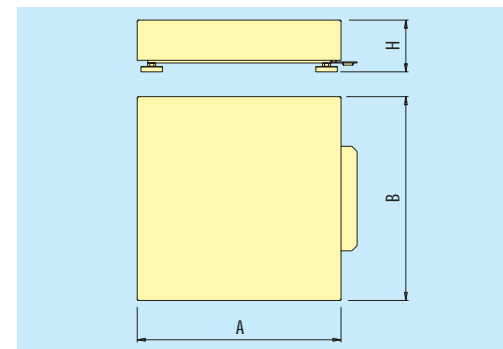

OFF CENTER load cells used in PMA range instruments

PMA with stainless steel load cell

Model	Dimensions (mm)			Basic Version Capacity (kg)	Basic Version Division (g)	Multirange Version Capacity (kg)	Multirange Version Division (g)	Max. preset tare (kg)	Weight (kg)
	A	B	H						
PMA 30.25	300	250	100	6	2	3/6	1/2	-	7
				12	2	-	-	8	
				15	5	6/15	2/5	5	
				30	10	15/30	5/10	20	
PMA 38.38	380	380	100	6	2	3/6	1/2	-	11
				12	2	-	-	6	
				15	5	6/15	2/5	3	
				30	10	15/30	5/10	20	
PMA 50.40	500	400	130	30	10	-	-	25	23
				60	20	-	-	-	
PMA 60.60	600	600	130	150	50	-	-	100	38
				300	100	-	-	50	
				60	20	-	-	-	
PMA 80.60	800	600	130	150	50	-	-	100	53
				300	100	-	-	50	
				60	20	-	-	-	

Technical specifications

- Stainless steel load cell with protection rating:
 - IP 67 for 30.25 and 38.38
 - IP 68 for 50.40; 60.60; 80.60
- AISI 304 stainless steel frame and platter
- Stainless steel adjustable feet

Optional equipment

- Mounting h=600 mm (for models 50.40; 60.60; 80.60)



SOCIETA' COOPERATIVA BILANCI

Weighing Instruments and Technologies

Società Cooperativa Bilanciai Campogalliano a.r.l.
41011 Campogalliano (MO) Italy - Via S. Ferrari, 16
Tel. 059/89.36.11 r.a. - Fax 059/52.70.79
Internet: www.coopbilanciai.it
E.mail cb@coopbilanciai.it

Platform scales



PMA model

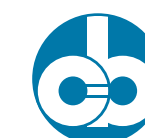

SOCIETA' COOPERATIVA BILANCI

PMA

General characteristics

PMA range platform scale are an indispensable instrument for a wide variety of uses, both in industry and for retail weighing.

Its main characteristics include sturdy design, easy use, simple installation and no maintenance. Built with robust metal frames protected against accidental overloading; they are equipped with adjustable feet to simplify levelling the instrument. Thanks to their versatility they can be used in processing and control lines. The weight is measured by an approved OFF CENTER load cell built in aluminum or stainless steel.

In the standard version, the platforms are built with aluminum cells and painted frame and platter (model 30.25 is built entirely of stainless steel, model 38.38 is equipped with stainless steel plate).

These versions are also available with stainless steel platter or completely stainless steel frame and platter.

For harsher environments PMA mod. platforms are manufactured completely in AISI 304 stainless steel with stainless steel load cells. It is possible to connect all the Coop. Bilanciai manufactured electronic terminals to the platforms. Weighing systems configured in this manner are equipped with CE marking in conformance with requirements in Directive 90/384 EEC.



PMA stainless steel version



PMA painted version

PMA standard version



OFF CENTER load cell used in PMA range instruments

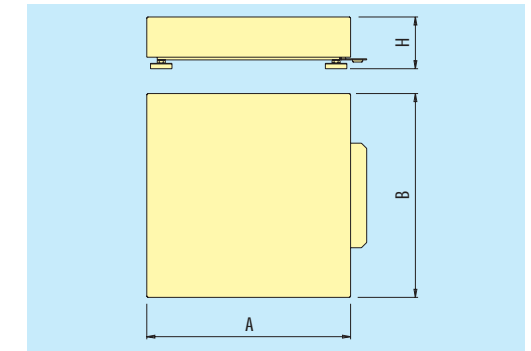

Painted PMA with aluminum load cell

Model	Dimensions (mm)			Basic Version Capacity (kg)	Basic Version Division (g)	Multirange Version Capacity (kg)	Multirange Version Division (g)	Max. preset tare (kg)	Weight (kg)
	A	B	H						
PMA 30.25 AISI 304 stainless steel frame and plate	300	250	100	6	2	3/6	1/2	-	5
				12	2	-	-	9	
				15	5	6/15	2/5	5	
				30	5	-	-	5	
				30	10	15/30	5/10	5	
PMA 38.38 Aluminum frame and AISI 304 stainless steel plate	380	380	100	6	2	3/6	1/2	-	5 (9)*
				12	2	-	-	9 (7)*	
				15	5	6/15	2/5	5 (3)*	
				30	5	-	-	5 (3)*	
				30	10	15/30	5/10	5 (3)*	
				60	20	30/60	10/20	10 (7)*	
PMA 50.40	500	400	130	30	10	-	-	35	20
				60	20	30/60	10/20	-	
				150	50	60/150	20/50	25	
PMA 60.60	600	600	130	60	20	30/60	10/20	-	35
				150	50	60/150	20/50	25	
				300	100	150/300	50/100	50	
PMA 80.60	800	600	130	60	20	30/60	10/20	20	50
				150	50	60/150	20/50	20	
				300	100	150/300	50/100	80	

(*) for AISI 304 frame and aluminum load cell

Technical specifications

- Aluminum load cell
- Painted frame and platter
- Model 30.25 entirely in AISI 304 stainless steel
- Model 38.38 AISI 304 stainless steel plate
- Stainless steel adjustable feet

Optional equipment

- AISI 304 stainless steel platter (for models 50.40; 60.60; 80.60)
- AISI 304 stainless steel platter and frame
- Mounting h=600 mm (for models 50.40; 60.60; 80.60) (CAPTIONS)